

Polycarbonate Security Cover for Rapier Series Diecast LED signs

Series PSR
PSR.09.08.3

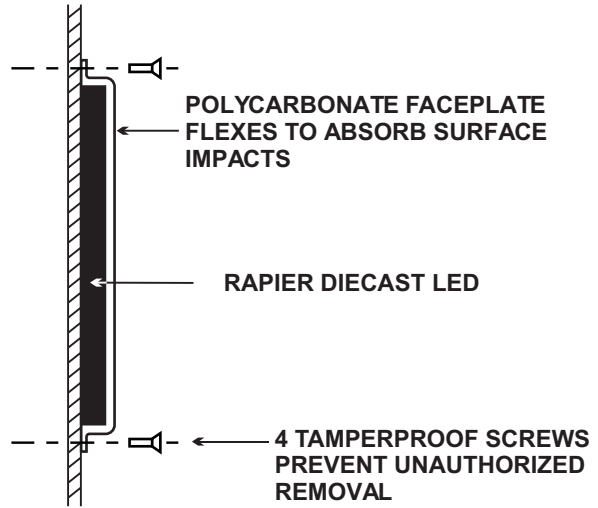

CONSTRUCTION

Clear polycarbonate enclosure with rounded corners to withstand high impact without damage. Tamper-proof screws prevent unauthorized removal.

WARRANTIES

5 year customer satisfaction warranty is provided against failure to meet required standards as specified on the product label. See catalog for complete details.

CODES AND APPROVALS

Manufactured and tested to UL Standard 924 for Floor Proximity Exit Signs, and Life Safety Code NFPA 101. Self luminous signs also meet requirements of National Electrical Code Article 500, Class I and II conditions.



FIXTURE SCHEDULE

MODEL	CATALOG NO
APPROVAL	JOB INFORMATION

Signtex Inc
LIGHTING
SPECIFIED EMERGENCY LIGHTING

Polycarbonate Security Cover for Rapier Series Diecast LED signs

Series PSR
PSR.09.08.3

SUGGESTED SPECIFICATIONS:

Furnish and install SIGNTEX Polycarbonate Security Cover, with 1/8" minimum wall thickness and 45 degree beveled edges on four sides. The cover shall meet impact tests and other requirements of UL Standard 924 for Floor Proximity Signs.

MOUNTING DATA & DIMENSIONS:

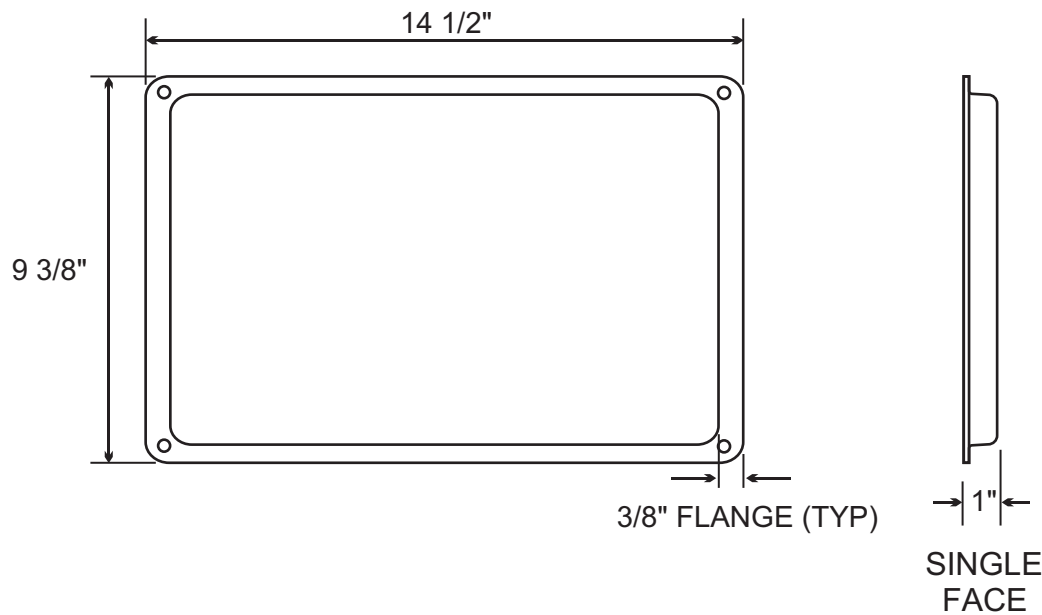

Signtex Inc
LIGHTING

220 VFW Avenue, Grasonville, MD 21638
TEL: (410) 827-8300 Fax: (410) 827-8866
sales@signtexinc.com www.signtexinc.com

DISTRIBUTOR:

--